



NEW PRODUCT UPDATE: Grip Strip II

January 2014

Part Number	Part	Length
3097	Soft Signage Grip Strip II	12'-2"

NEW PROFILE

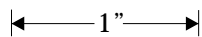

PREVIOUS PROFILE

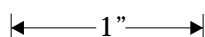

Features & Benefits

- Eliminates the need to use silicone beads.
- New softer material will not damage delicate fabrics.
- Improved Grip Strip works with all popular fabrics.
- No special tensioning tool required.
- Insert fabric with any narrow vinyl squeegee.
- Grip Strip is used in all four frames.
 - 2" Soft Signage Tension Frame (Part #3090)
 - 1-1/4" Soft Signage Tension Frame (Part #3090N)
 - 2" Soft Signage Snap Tension Frame (Part #3091)
 - 1-1/4" Soft Signage Snap Tension Frame (Part #3091N)

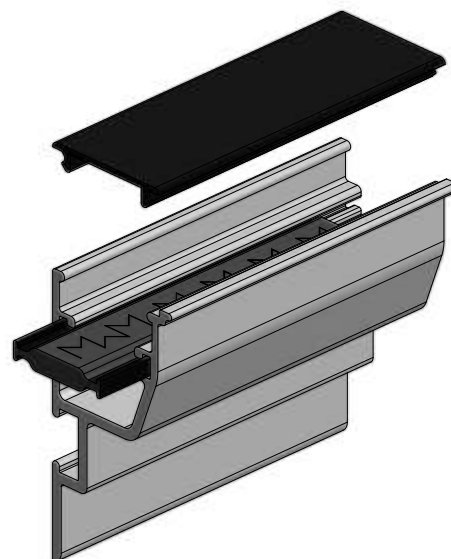
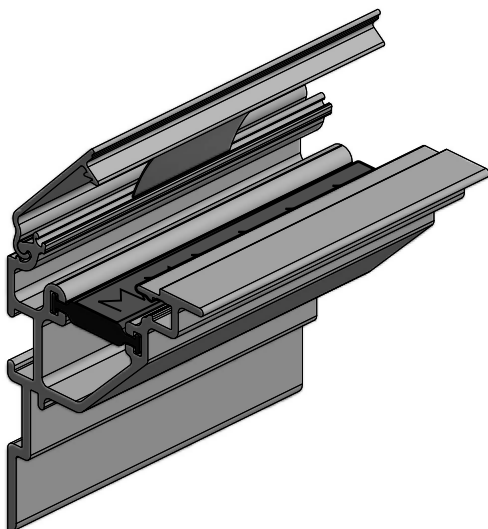

US Patent Number 8,595,966